

# N280

## KNURLED INDEXING KNOB WITH STEPLESS POSITIONING



### Materials:

1. Stainless steel (AISI 304) fixing base with friction device seat and fixing holes.
2. Aluminium graduated flange (alloy 2011).
3. Reinforced polyamide control knob. Resistant to oils and greases.
5. PA6 cap.
6. Stainless steel fastening cap with hexagon socket (Aisi 303).
7. Fastening snap ring in stainless steel (UNI 3653).
8. Stainless steel (AISI 304) lock and friction mechanism.
10. Stainless steel self-tapping screws (AISI 303) TCS 2.9x13 for fastening the flange.

### Surface finish:

- 1-6-7-8. Glossy.
2. Anodized.
- 3-5. Satin.

### Colour:

1. Natural with engraved arrow.
2. Anodized black.
3. Black (RAL 9011).
5. Grey (RAL 7035 code 13).
7. Black-oxide treated.
- 6-8. Natural.

### Fastening to the machine:

Fixed to the machine with 3 x M5 hex socket head cap screws (number 9 in the drawing) (DIN 912).

### Graduated flange:

The standard numbering of the flange goes from 0 to 9 with 10 graduations for each unit. (100 graduations). Specific custom graduations are available for a minimum quantity of 30 pieces.

### Coupling of the shaft to the knob:

The shaft is coupled to the knob by means of a shaft with keyway. Attention! The key, for technical reasons, is small in size. See attached diagram for bore/shaft dimensions.

### Hole:

The shaft hole is machined to H7 tolerance. Side fixing hole is not required. The diameter of the hole is fixed and cannot be varied.

### Special requests:

- Central cap available upon request in the colours indicated in the chart on [page ].
- The flange with customised numbering is available upon request and for special quantities (30 pieces).

### Features:

The main feature of this item is the possibility to continually adjust the axis of the machine to which it is coupled and to maintain the selected position. The special friction device, the heart of the mechanism, allows you to make very small, continuous movements and therefore enables fine tuning in both directions. After reaching the desired position, the friction device prevents rotation by any minor shaft-induced vibrations or movements. This system prevents accidental or involuntary rotations of the shaft.

### Limitations:

If the vibrations are strong the friction device is not sufficient to block any movements. Moreover, the knob cannot support the weight of the shaft, consequently it does not replace the normal support systems (bearings, flanges, etc.). The knob cannot be installed if there is a motor drive present.

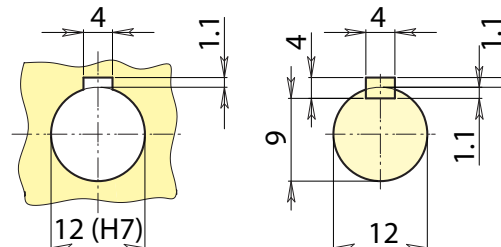

Lowered key in compliance with DIN 6885-2

# N280

## KNURLED INDEXING KNOB WITH STEPLESS POSITIONING



PA6  
+G.F.

UL94  
HB

RoHS  
COMPLIANT

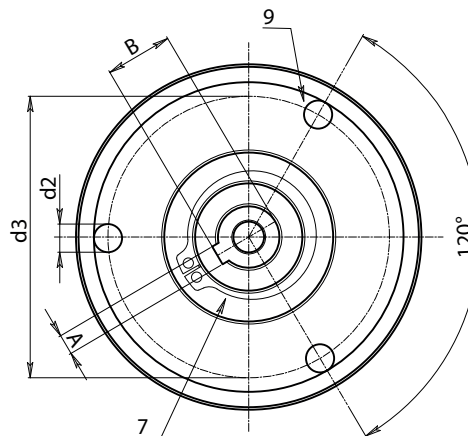
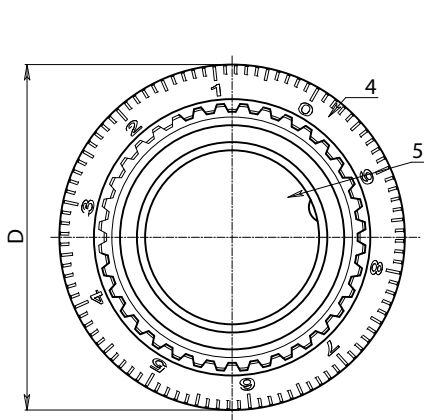
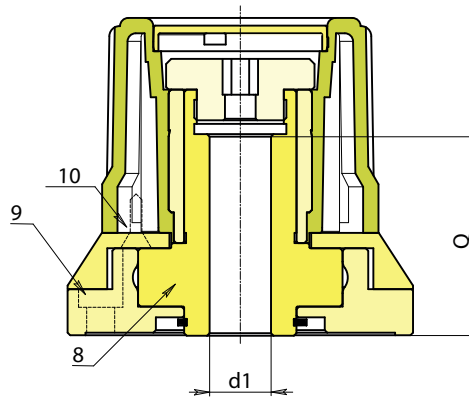
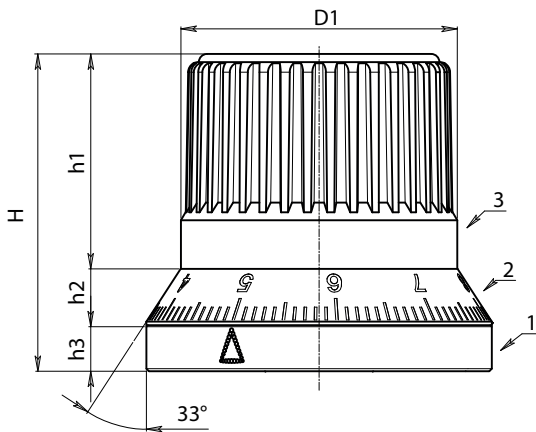

Code	Art.	D	H	D1	h1	h2	h3	d3	d2	A	B	d1H7	Q	g
-	N28054.HNZ1000113CIN	67,5	62	54	42	11	9	55	5,5	4	13,1	12	39,5	535