

G735



4-LOBE HANDWHEEL WITH ELONGATED HUB AND THREADED STUD

Materials:

Reinforced polyamide. Resistant to oils and greases.

Surface finish:

Satin.

Colour:

Black (RAL 9011).

Inserts:

Galvanised steel threaded stud (thread tolerance 6g).

Special requests:

- Upon request and for special quantities inserts can be supplied with customised lengths.
- Upon request and for special quantities inserts can be supplied in different materials.
- Upon request and for special quantities handwheels can be supplied with custom hubs.



07

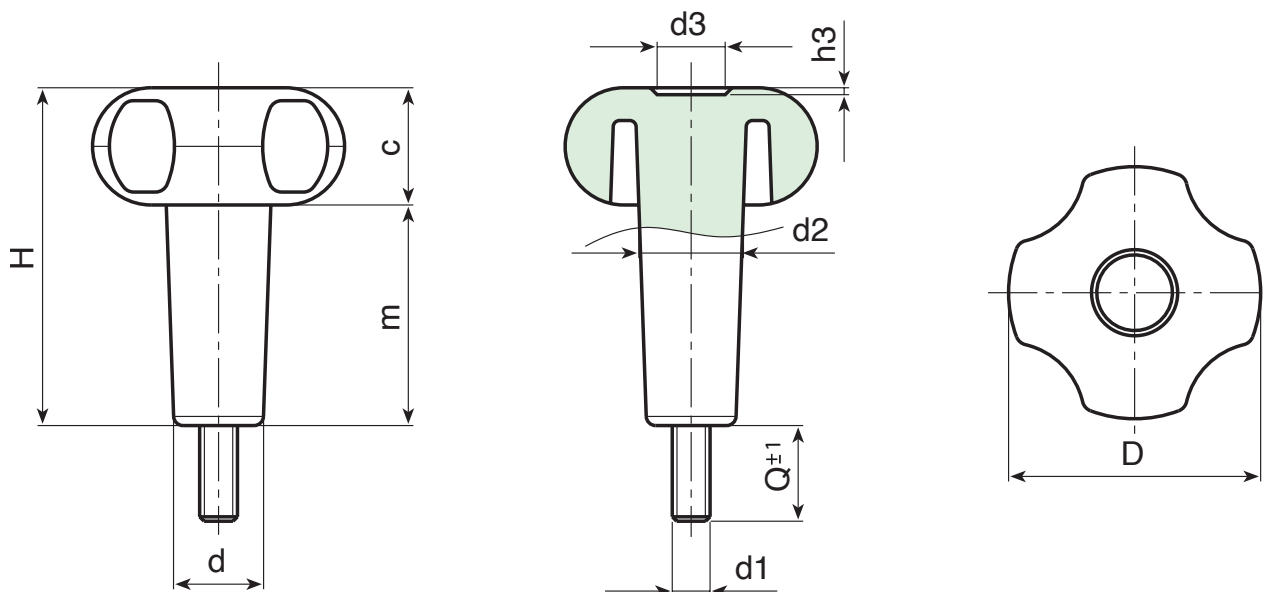

Code	art.	D	H	m	d	c	d2	d3	h3	LM	d1 _{6g}	Q	
G73530.0008	G73530.T35M06X1501	30	47	33.5	13.5	14	15	12	2	65	M6	15	23
G73530.0013	G73530.T35M08X3001	30	47	33.5	13.5	14	15	12	2	65	M8	30	36
G73540.0003	G73540.T35M08X2001	41	54	35	16.5	19	17	12	3	80	M8	20	49
G73540.0013	G73540.T35M10X1501	41	54	35	16.5	19	17	12	3	80	M10	15	54
G73550.0009	G73550.T40M08X1501	52	61	39	17.5	22	19	14	2.5	90	M8	15	60
G73550.0028	G73550.T40M10X4001	52	61	39	17.5	22	19	14	2.5	90	M10	40	82
G73550.0047	G73550.T60M08X3001	52	80	58	18	22	21	14	2.5	70	M8	30	86
G73560.0018	G73560.T60M10X4001	59	83	58	23	25	24	24	4	75	M10	40	138

LM = Maximum mouldable length.

Customised stud length available for a minimum of 100 pieces.

