

R408



POLYPROPYLENE / RUBBER WHEEL WITH RECTANGULAR SWIVEL STEEL PLATE WITH BRAKE

Materials:

Wheel body:

Polypropylene.

Tread:

Synthetic thermoplastic rubber. Hardness 93 ± 3 Shore A.

Surface finish:

Smooth.

Colour:

(1) Black (RAL 9011).

(2) Light grey.

(3-4-5-6-7) Galvanised blue.

Wheel rotation (4):

The hole for the pivot pin is formed by plastic moulding. A galvanised steel tube is positioned between the stud and the hole for protection.

Bracket (3):

Steel fork (DD13), with integrated brake. Brake actuation lever moulded in grey plastic.

Rotating assembly (5):

Steel rotating assembly with double ball race, and rectangular swivel plate with four slotted mounting holes.

Wheel fastening (6):

Steel hex head screw, coupled with a steel nut.

Thread guards (7):

Sheared steel thread guard disk fixed on both sides.

Special requests:

- None.

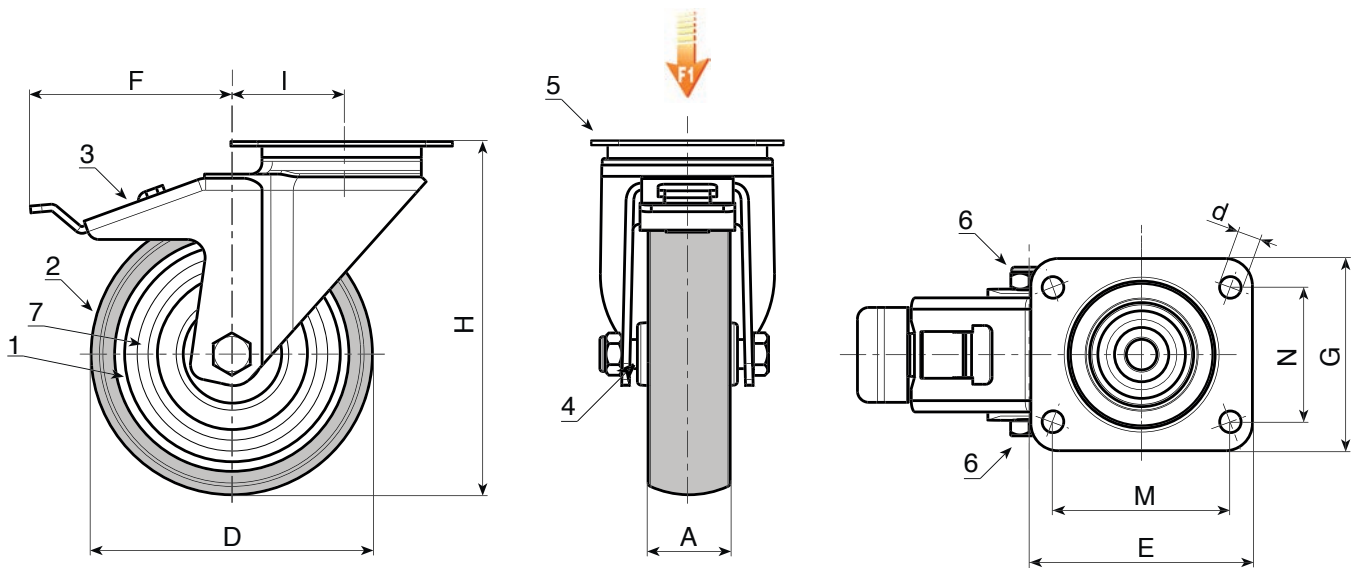

Code	art.	D	A	H	I	E	G	M	N	d	F	g	F1 (Kg)
R408050.0001	R408050.T18P045X045	50	18	70	26	60	60	45	45	6,5	84	-	40
R408063.0001	R408063.T22P045X045	63	22	90	26	60	60	45	45	6,5	84	-	60
R408080.0001	R408080.T22P045X045	80	22	109	25	60	60	45	45	6,5	84	-	60
R408100.0001	R408100.T27P060X050	100	27	134	36	76	70	60	50	8,3	106	-	80
R408125.0001	R408125.T27P060X050	125	27	159	35	76	70	60	50	8,3	106	-	80